



**Rasmussen**<sup>®</sup>  
THE GAS LOG COMPANY

# ADDENDUM TO PRODUCT INSTRUCTIONS

## DOUBLE FACE BURNER ASSEMBLY INSTRUCTIONS

REV DFFB 0709  
Last Printed 4/27/2010

12028 E. PHILADELPHIA ST.  
WHITTIER, CA CALIFORNIA 90601 U.S.A.  
www.rasmussen.biz

### ATTENTION! READ INSTRUCTIONS CAREFULLY BEFORE ASSEMBLY

#### REQUIRED TOOLS AND MATERIALS

Adjustable Wrench, Pipe Wrench, Flat Head Screwdriver, Pipe Sealing compound (Only required if fittings are not already prepared with pre-wrapped Teflon thread tape). **NOTE:** If fittings do not come pre-wrapped with Teflon threaded tape, pipe compound **MUST** be applied to all tapered pipe threads to prevent gas leaks. **DO NOT** use Teflon tape or pipe compound on *any* flared fitting threads.

#### REQUIRED PARTS

- |                          |                              |                         |                         |
|--------------------------|------------------------------|-------------------------|-------------------------|
| 1) 48-8-8 Orifice Holder | 5) 1/2" Street Elbows        | 9) Orifice Holder (A2T) | 13) Air Mixer (MA2)     |
| 2) 1/2" X 3/8" Bushing   | 6) Orifice                   | 10) V17 Valve           | 14) 1/2" x Close Nipple |
| 3) 2 - 3/8" Burner Plugs | 7) Damper Clamp              | 11) 3/8" Street Elbow   |                         |
| 4) 1/2" T                | 8) Rating Plate/ Heat Shield | 12) V17 Valve Key       |                         |

#### STANDARD MATCH LIGHTED (NATURAL GAS MODELS ONLY, Page 3)

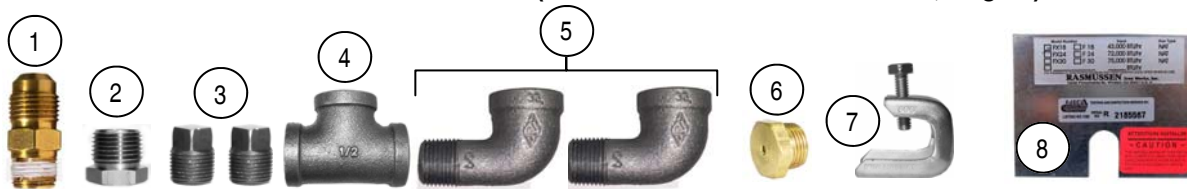

#### OPTIONAL ACCESSORY MATCH LIGHTED WITH MANUAL V17 VALVE (NATURAL GAS MODELS ONLY, Page 4)

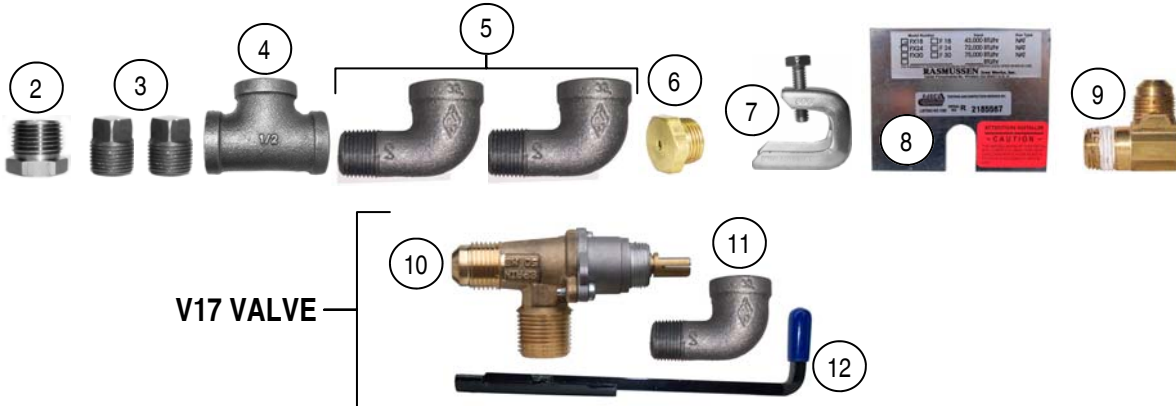

#### NATURAL GAS MODELS USING THE OPTIONAL "EASY" SAFETY PILOT CONTROL (Page 4)



#### ALL DOUBLE FACE PROPANE MODELS (Page 5)



**REMINDER: Pipe compound must be applied to all non-flared threads if not pre-wrapped with Teflon threaded tape.**

### **STEP ONE: BURNER PAN PLACEMENT:**

- 1) Place Burner Pans back to back (Figure 1A) with about a 2" space between them (Figure 1B), and, using an adjustable wrench, thread the 3/8" Burner Plugs (Figure 1C) into same side of both Burner Pipes (Figure 1D) and tighten.

**FIGURE 1**

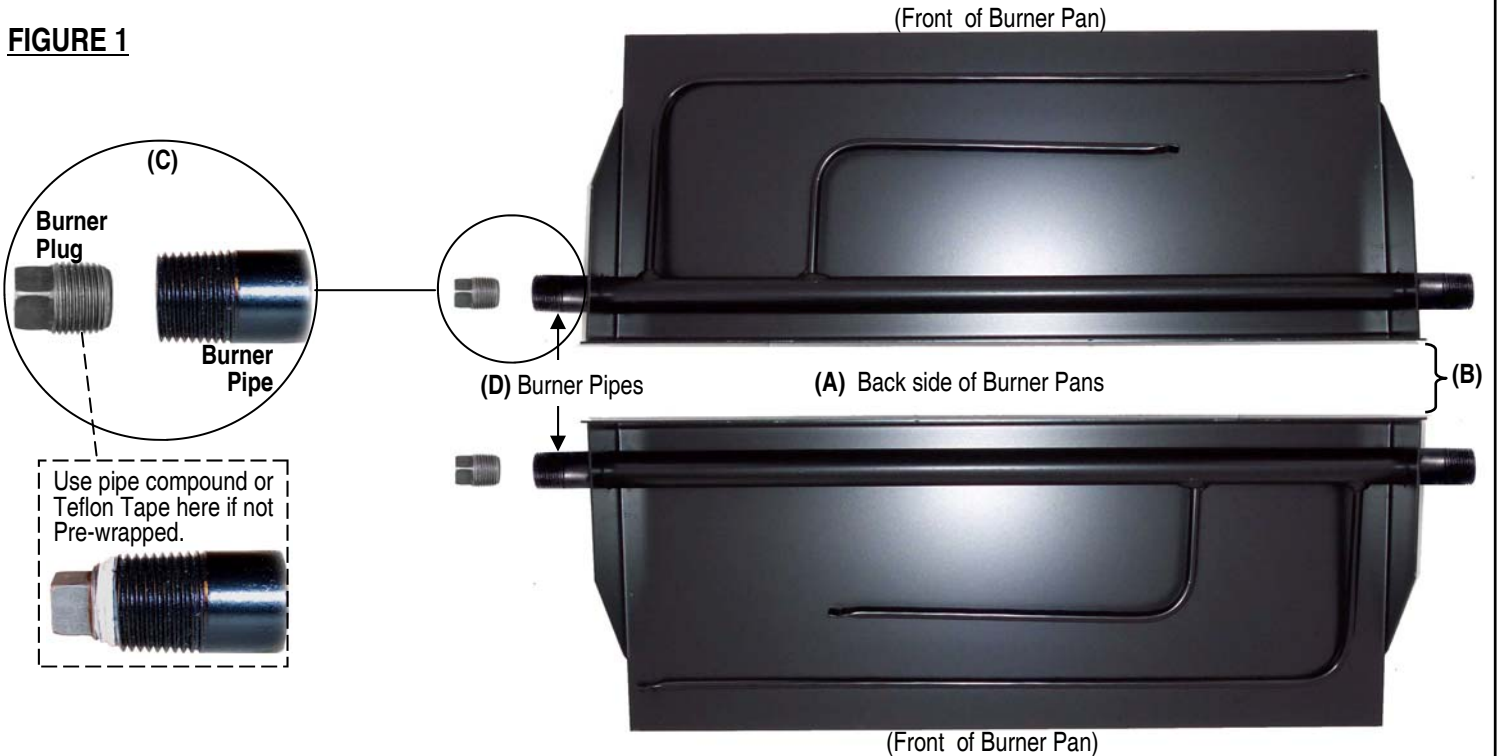

### **STEP 2: CONNECTOR ASSEMBLY**

- 1.) Thread both the 1/2" Street Elbows (Figures 2A and B) into the 1/2" TEE (Figure 2C). Completely tighten one 3/8" Street Elbow using pipe wrench but leave second one facing upward before completely tightening (Figure 3).

**FIGURE 2**

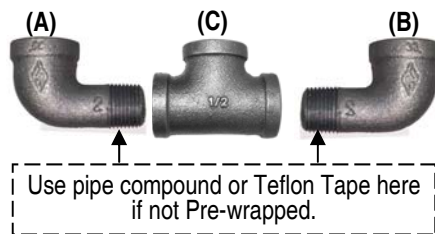
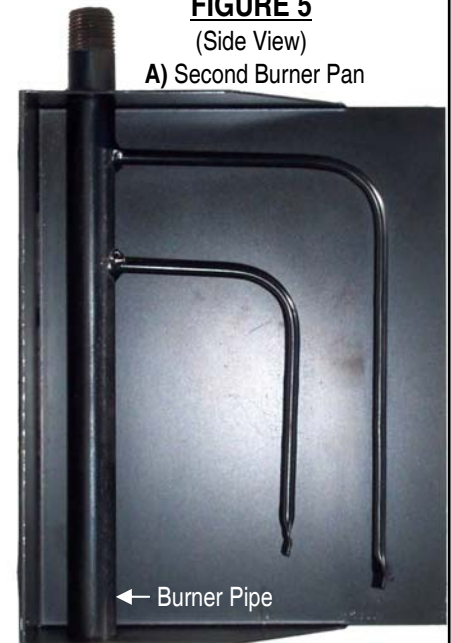

**FIGURE 3**



**FIGURE 5**

(Side View)  
A) Second Burner Pan



### **STEP 3: ATTACH CONNECTOR ASSEMBLY TO BURNER PANS**

- 1.) Thread the connector assembly onto one burner pipe turning whole assembly clockwise, saving the 1/2" Street Elbow facing upward for the second burner.
- 2.) Next, thread the second burner pan (Figure 5A) into the 1/2" Street Elbow left facing upward (Figure 5B), again turning clockwise. Once tightened, lower second burner pan so both pans are again side by side (Figure 6).

**FIGURE 4**

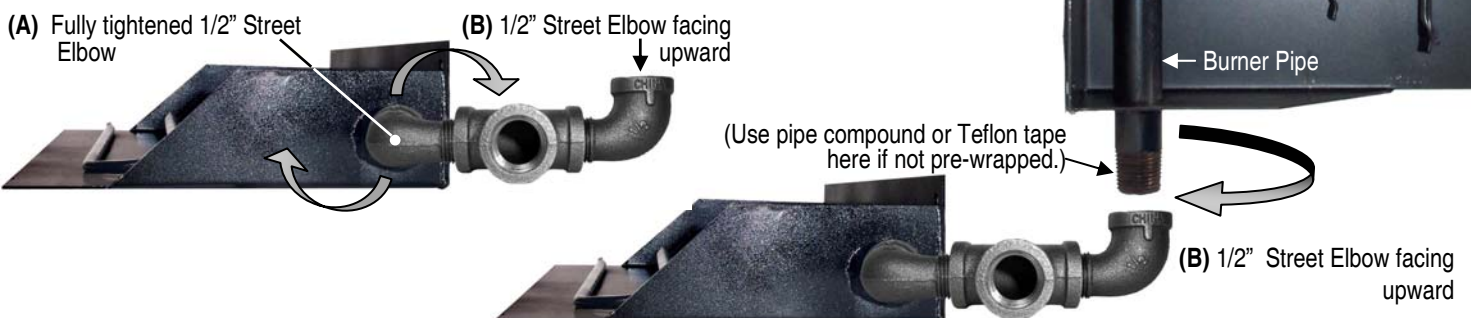

ONCE COMPLETED THE DUAL BURNER ASSEMBLY SHOULD LOOK LIKE THE ILLUSTRATION BELOW.

**FIGURE 6**  
(Top View)



**STEP 4: BURNER CONTROL ASSEMBLY  
STANDARD MATCH LIGHTED (NATURAL GAS MODELS ONLY)**

**NOTE:** If fittings do not come pre-wrapped with Teflon threaded tape, pipe compound **MUST** be applied to all tapered pipe threads (except in Step 2) to prevent gas leaks. **DO NOT** use Teflon tape or pipe compound on *any* flared fitting threads.

1. Thread **1/2" X 3/8" Bushing** (Figure 7A) into the **1/2" T** (Figure 7B) and wrench tighten.
2. Thread **Orifice Spud** (Figure 7C) into **48-8-8 Orifice Holder** (Figure 7D) (Do not use pipe compound or Teflon tape here).
3. Thread Orifice Holder into **1/2" X 3/8" Bushing** and wrench tighten into position shown (Figure 8).
5. Insert the **Rating Plate/Heat Shield** (Figure 8A) between the **1/2" X 3/8" Bushing** and **48-8-8 Orifice Holder**, with labels facing away from burner.

Refer to your "Flaming Ember Instructions for gas supply connection, lighting instructions and important guidelines.

**FIGURE 7**  
(Top View)

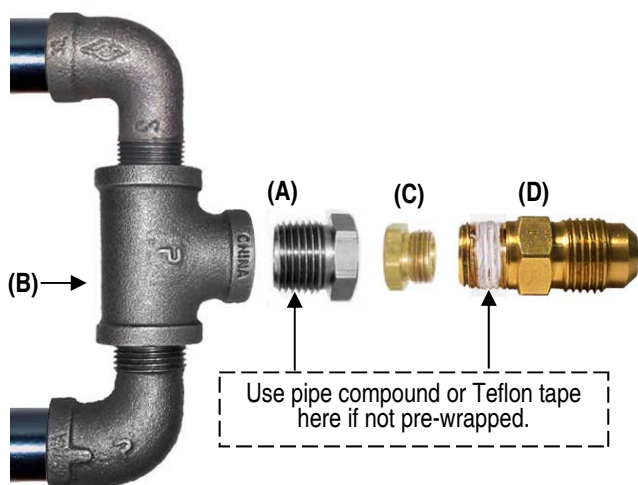

**FIGURE 8**  
(Top View)

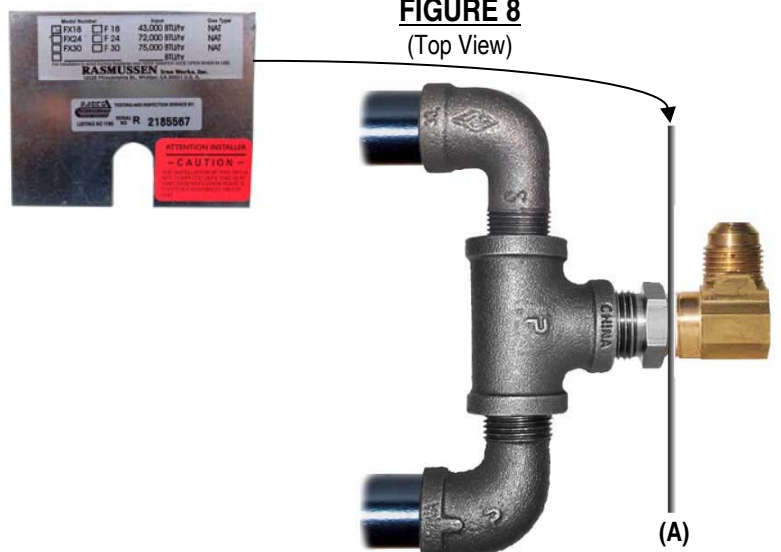

## STEP 4: OPTIONAL ACCESSORY MATCH LIGHTED WITH MANUAL “V-17” VALVE (NATURAL GAS MODELS ONLY)

**NOTE:** If fittings do not come pre-wrapped with Teflon threaded tape, pipe compound **MUST** be applied to all tapered pipe threads (except in Step 3) to prevent gas leaks. **DO NOT** use Teflon tape or pipe compound on *any* flared fitting threads.

1. Thread the **1/2” X 3/8” Bushing** (Figure 9A) into the **1/2” T** (Figure 9B) and wrench tighten.
2. Thread the **3/8” Street Elbow** (Figure 9C) into the 1/2” X 3/8” Bushing. Wrench tighten till facing upward as shown below (Figure 9C).
3. Thread the **Orifice Spud** (Figure 9D) (**Without** using pipe compound or Teflon tape) into the **V-17 Valve** (Figure 9E), then thread the V17 Valve into the **3/8” Street Elbow** and wrench tighten.
4. Insert **Key Sleeve** (Figure 9F) over **V-17 Valve Stem** (Figure 9G)
5. Insert rating plate (Figure 9H) between the 1/2” X 3/8” Bushing and the 3/8” Street Elbow.

Refer to your “Flaming Ember Instructions for gas supply connection, lighting instructions and important guidelines.

**FIGURE 9**

(Side View)

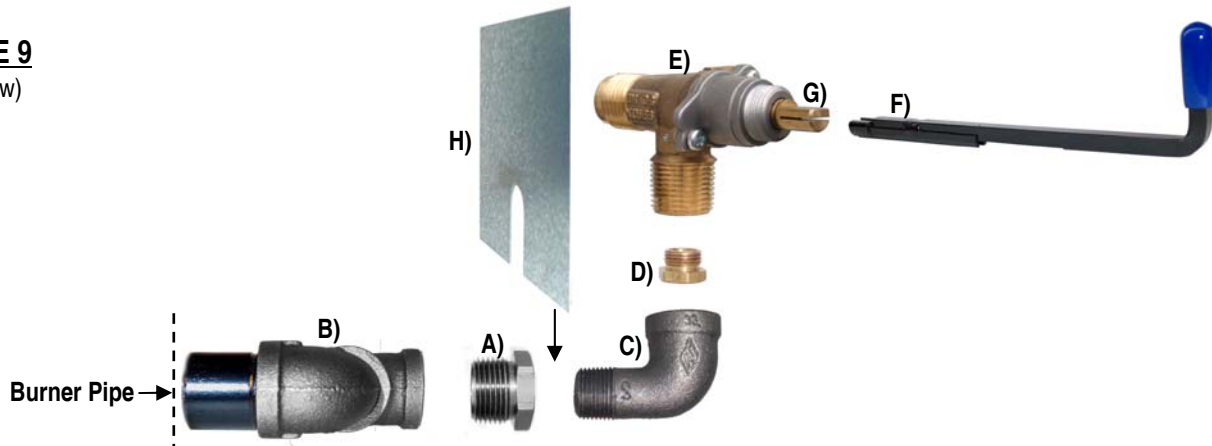

## STEP 4: OPTIONAL “EASY” SAFETY PILOT CONTROL (NATURAL GAS MODELS)

### **WARNING:**

**AN “EASY” SAFETY PILOT CONTROL MUST BE INSTALLED ON ALL UNITS DESIGNED OR CONVERTED TO BURN PROPANE GAS. THE “EASY” SAFETY PILOT CONTROL IS OPTIONAL FOR NATURAL GAS UNITS.**

For “EASY” Safety Pilot Control assembly, important guidelines, installation, placement and lighting refer to your “Flaming Ember” instructions as well as the individually supplied instructions for the “SPK3E”, “RPK3E” or RMC1E”.

1. Thread **1/2” X 3/8” Bushing** (Figure 10A) into the **1/2” T** (Figure 11B) and wrench tighten.
2. Thread the **Orifice Spud** (Figure 10C) (**Without** using pipe compound or Teflon tape) into the **3/8” Orifice Holder** (Figure 10D)
3. Thread the 3/8” Street Elbow into the 1/2” X 3/8” Bushing and wrench tighten into position shown (Figure 10D).

**NOTE:** Attachment of the Rating Plate (Figure 10F) is optional when using the “EASY Safety Pilot Control. The Rating plate may be placed under one of the burner pans or kept with your instructions for future reference.

**FIGURE 10**

(Top View)

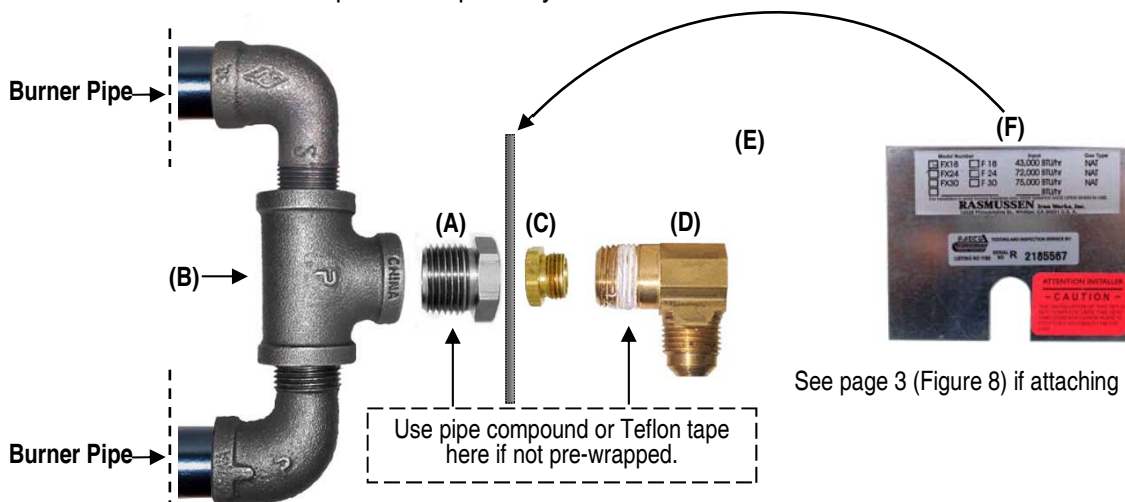

See page 3 (Figure 8) if attaching rating plate

## STEP 4: OPTIONAL "EASY" SAFETY PILOT CONTROL (PROPANE)

### WARNING:

AN "EASY" SAFETY PILOT CONTROL MUST BE INSTALLED ON ALL UNITS DESIGNED OR CONVERTED TO BURN PROPANE GAS. THE "EASY" SAFETY PILOT CONTROL IS OPTIONAL FOR NATURAL GAS UNITS.

For "EASY" Safety Pilot Control assembly, important guidelines, installation, placement and lighting refer to your "Flaming Ember" instructions as well as the individually supplied instructions for the "SPK3E", "RPK3E" or "RMC1E".

**NOTE:** If fittings do not come pre-wrapped with Teflon threaded tape, pipe compound MUST be applied to all tapered pipe threads (except in Step 3) to prevent gas leaks. **DO NOT** use Teflon tape or pipe compound on *any* flared fitting threads.

### PROPANE MODELS ONLY)

1. Thread the third **1/2" Elbow** (Figure 10A) into the **1/2" T** (Figure 10B) and wrench tighten.
2. Thread the **1/2" x Close Nipple** (Figure 10C) into the **1/2" Elbow** and wrench tighten.
3. Thread the **Air Mixer** (Figure 10D) onto the **1/2" X Close Nipple**.
4. Thread the **Orifice Spud** (Figure 10E) (**Without** using pipe compound or Teflon tape) into **3/8" Orifice Holder** (Figure 10F)
5. Thread the **3/8" Orifice Holder** into the Air Mixer.
6. Insert the Rating plate (Figure 10G) between the Air mixer and the orifice holder.

**NOTE:** Attachment of the Rating Plate is optional when using the "EASY Safety Pilot Control. The Rating plate may be placed under one of the burner pans or kept with your instructions for future reference.

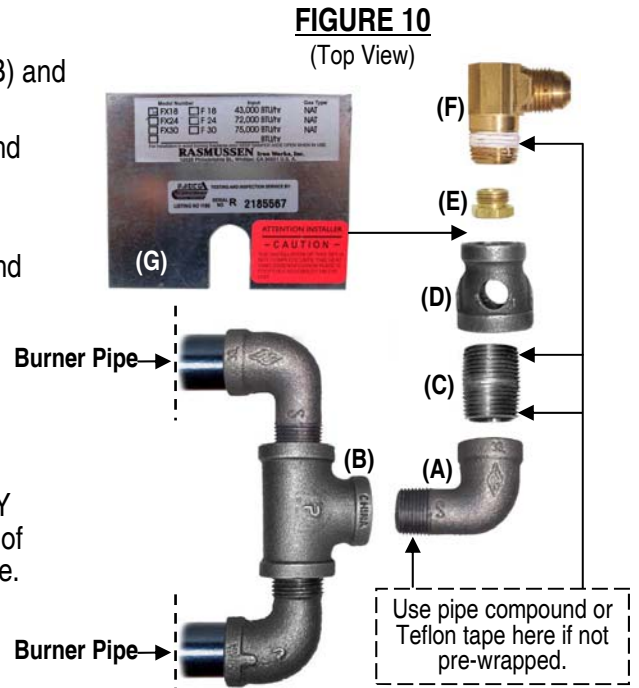

### Examples of Assembled Double Face Burners

(Double Face FX24 Model with "Easy" Safety Control shown below for example)

For "EASY" Safety Pilot Control assembly, important guidelines, installation, placement and lighting refer to your "Flaming Ember" instructions as well as the individually supplied instructions for the "SPK3E", "RPK3E" or "RMC1E".

Completed Double Face **Natural Gas** Assembly with "EASY" Safety Pilot Control attached.

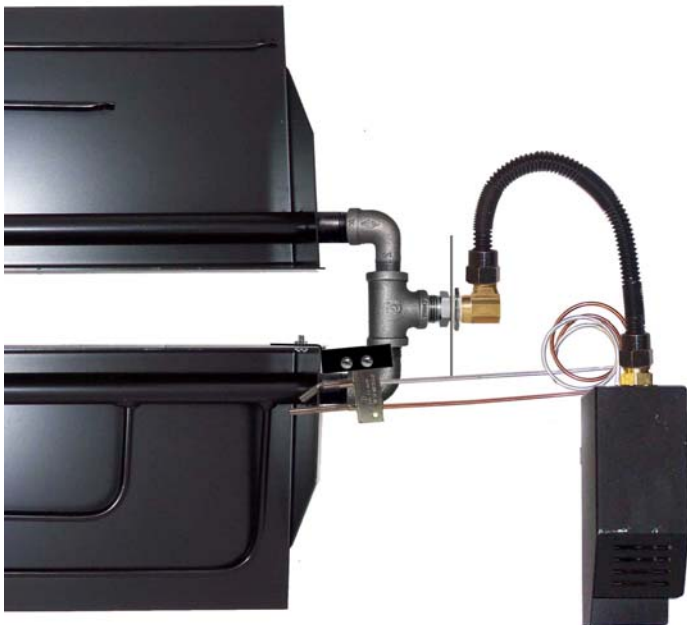

Completed Double Face **Propane** Gas Assembly with "EASY" Safety Pilot Control attached.

