



Rasmussen
THE GAS LOG COMPANY

SPK3-CS/CA

12028 E. Philadelphia St. Whittier, CA 90601 U.S.A.
(562) 696-8718 FAX (562) 698-3510
E-Mail: gaslogs@riwinc.com Web http://www.riwinc.com

SPK3-CS/CA599

LISTED BY



LISTING NO. 1180

Assembly, Installation, and Operation Instructions for
SPK3-CS (NATURAL GAS) or SPK3-CA (PROPANE GAS) Safety Pilot

ATTENTION! READ INSTRUCTIONS CAREFULLY BEFORE ASSEMBLY.

Required Tools and Materials.

Adjustable Wrench, Pipe Wrench, Screw Driver, Pipe sealing compound, Matches.

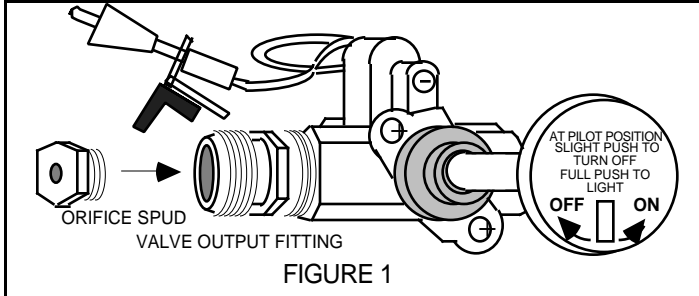

FIGURE 1

STEP ONE: Insert Burner Orifice.

1. Thread **ORIFICE SPUD** into **VALVE OUTPUT FITTING** and wrench tighten. **DO NOT USE PIPE COMPOUND WHEN INSERTING ORIFICE.**

NOTE: Maximum flame height can be adjusted by changing orifice size, e.g., a larger orifice results in a larger flame.

SUGGESTED ORIFICE SIZES

BURNER SIZE	18"	24"	30"	36"
NAT. GAS ORIFICE SIZE	#36	#28	#28	#25
LP. GAS ORIFICE SIZE	#53	#49	#45	#42

STEP TWO: Attach Valve to Burner Pan.

1. Apply Pipe Compound to outside threads of the **VALVE OUTPUT FITTING**. Do not allow pipe compound to clog orifice. Insert **VALVE** into **BURNER PAN REDUCING COUPLING/AIR MIXER** and using wrench placed onto **VALVE** at the **WRENCH ATTACH POINT**, tighten to position shown at Figure Two.

STEP THREE: Attaching Pilot-Thermocouple Assembly.

1. Align the **PILOT-THERMOCOUPLE ASSEMBLY** on side of **BURNER PAN** as shown in Figure Three. Using **NUT** and **BOLT** through pre-punched hole in side of burner pan, attach **ANGLE BRACKET** ensuring that the **PILOT BURNER** is located beyond the side and inside the **BURNER PAN**. (Figure Three)

ATTENTION: To ensure correct operation of the **PILOT**, the **THERMOCOUPLE LEAD** and **PILOT TUBING** should be coiled away from the **BURNER PAN**.

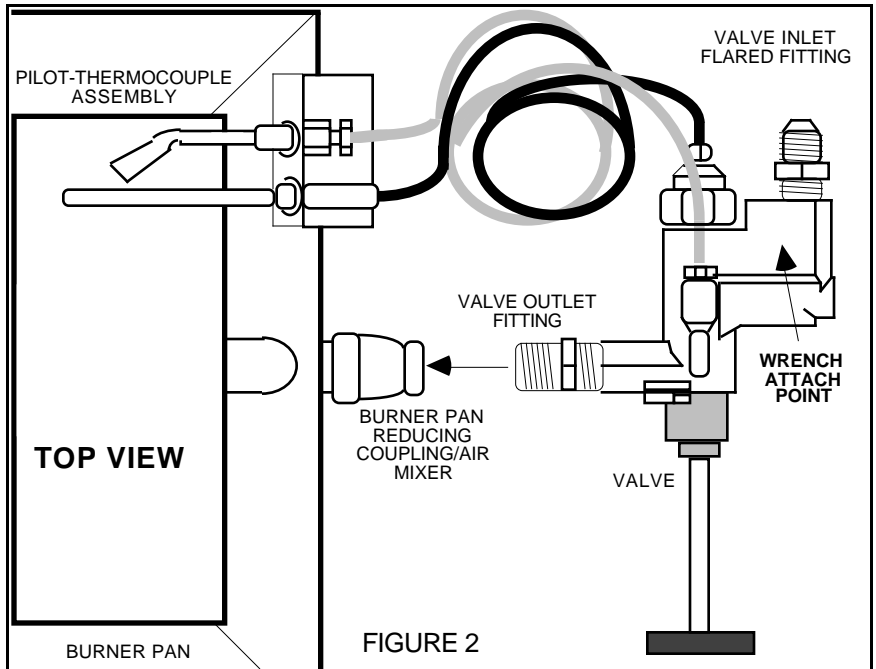

FIGURE 2

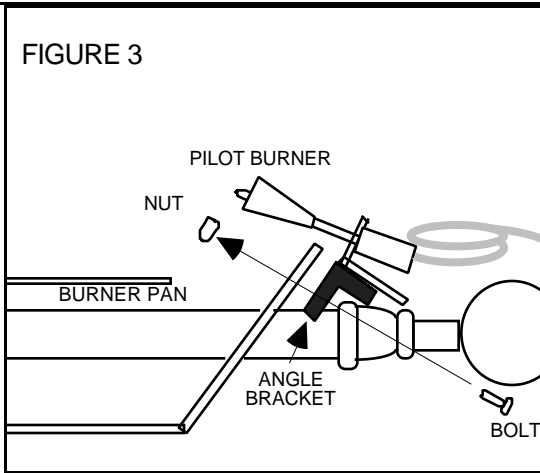

FIGURE 3

STEP FOUR: Install Heat Shield.

1. With the notched end over the **VALVE OUTPUT FITTING**, place the **HEAT SHIELD** over the **VALVE** as shown in Figure Four.

WARNING: HEAT SHIELD MUST BE INSTALLED TO PREVENT PREMATURE VALVE FAILURE AND/OR VOIDING OF VALVE MANUFACTURER'S WARRANTY

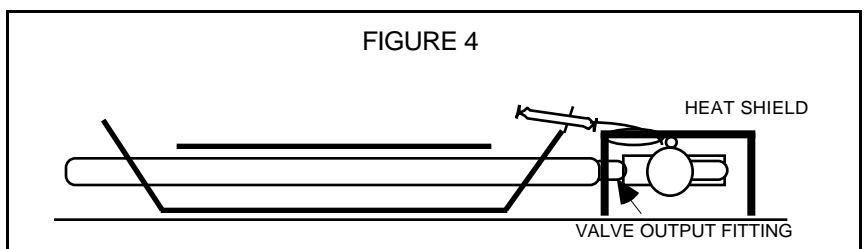

FIGURE 4

OPERATION AND SPECIFICATIONS

SPK3-CS/CA SAFETY PILOT

LISTED BY



LISTING NO. 1180

ATTENTION!

**ALL PIPING AND TUBE JOINTS MUST BE TESTED FOR LEAKAGE
DAMPER AND GLASS DOORS MUST BE FULLY OPEN BEFORE LIGHTING
OR BURNING FOR PROPER VENTILATION AND TO PREVENT
HEAT DAMAGE TO VALVE**

**HEAT SHIELD MUST BE INSTALLED TO PREVENT PREMATURE VALVE FAILURE
AND/OR VOIDING OF VALVE MANUFACTURER'S WARRANTY**

**WARNING: This Safety Pilot is intended for use with a Natural Gas Burner.
Ensure Burner Pan is filled with the white sand supplied with the Burner.**

LIGHTING INSTRUCTIONS.

1. Bleed all air from piping leading to control. Carefully re-tighten connection.
2. Turn **CONTROL KNOB** pointer to "OFF" position. Wait 5 minutes before lighting.
3. Turn **CONTROL KNOB** pointer to "PILOT" position. Depress **CONTROL KNOB** and hold down 60 seconds after lighting pilot burner. Release **CONTROL KNOB**. Pilot will remain lighted.
4. Turn **CONTROL KNOB** partially towards the "ON" position. After gas fills burner pan medium, burner will light. Dial may then be turned to full "ON" or to desired flame height
5. If main or pilot burner extinguishes, turn **CONTROL KNOB** to "OFF" position. Wait five minutes and repeat above lighting

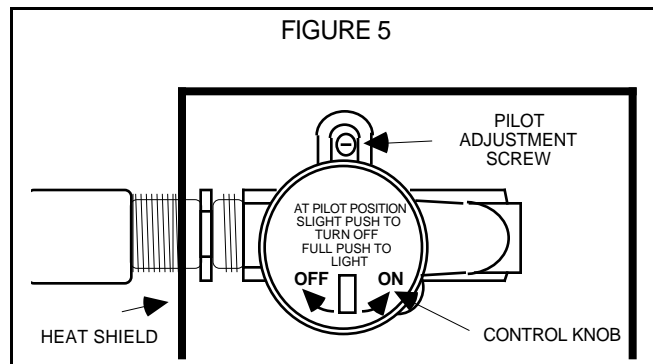

procedure from step 1.

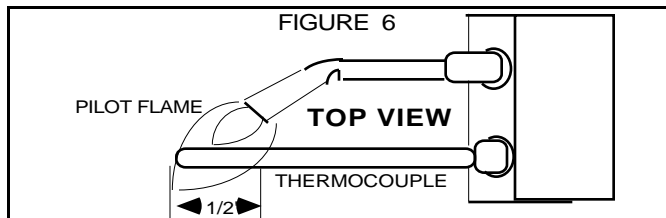

PILOT ADJUSTMENT.

1. Adjust Pilot if necessary. With narrow long stem screw driver, turn **PILOT ADJUSTMENT SCREW** clockwise to reduce size of pilot flame or counterclockwise to increase flame.

Correctly adjusted pilot flame should be steady and soft blue surrounding approximately 1/2 inch of thermocouple tip. Never permit tip to exceed a dull red temperature. (See Figure Six)

VALVE SPECIFICATIONS.

Maximum valve operating pressure is 1/2 PSI (14" WC)
Maximum valve capacity is 129,000 BTU

Maximum ambient temperature is 300° F
AGA certified to ANSI Z 21.20 and ANSI Z 21.15

SERVICE AND TROUBLESHOOTING.

Analysis and correction of control service problems must be made by qualified gas service men only. Attempts to service or repair the Safety Pilot by other than authorized service personnel will void the manufacturer's responsibility and guarantee. In general, failure of control to operate may be due to the reasons noted below:

1. Pilot will not light initially:
 - Check for loose thermocouple Terminal Nut connection.
 - Check for improper pilot flame adjustment.
 - Check that Dial is fully depressed during pilot lighting operation and held depressed for 60 seconds after lighting.
 - Check for defective thermocouple.
 - Check for defective thermo magnet unit.
2. Pilot / main burner clicks off after 5 to 30 minutes of burning:
 - Valve and thermocouple are not defective, otherwise pilot would not initially light.
 - Thermocouple is losing temperature difference between hot tip and cold junction (base).
 - Check that thermocouple assembly is installed on side of burner on bracket per instructions.
 - Check that only tip of thermocouple is in main burner flame.
 - Remove then replace logs to alter heat radiation pattern. Ensure that glass doors are open.
 - Ensure that proper size gas log set is installed. Too large of a set decreases cooling air flow.